

Load sensing hydraulic system for drilling rig based on amesim

DONGMIN LI^{2,3,4,5}, YANQIANG ZHANG³, JIA LI³, GUOFANG MA³, MENGQUAN SHANG³

Abstract. Aiming at sticking for drilling rod used on a typical drilling rig, a load sensing system is built on drilling rig after analysis on the hydraulic system of drilling rig, and it is modeled with AMESIM, besides the control method based on fuzzy PID is proposed for the hydraulic system. The simulation results show that the hydraulic system can deal with the drilling for the drilling rod effectively.

Key words. Drilling rig, sticking for drilling rod, load sensing, fuzzy theory, pid.

1. Introduction

A typical drilling rig is characterised with low speed and high torque, and capable of drilling large-diameter hole underground coal mine. The drilling rig can drill the large-diameter gas drainage holes and other engineering holes underground coal mines, and it consists of three parts, i.e., the host, hydraulic pump station and operation console^[1–3].

Sticking for the drilling rod due to geology, stress and other reasons during the

¹Acknowledgement - This work was supported by Open Fund from State Key Laboratory of Mine Disaster Prevention and Control Co-founded by Shandong Province and the Ministry of Science and Technology (Grant No. MDPC201609), Open Foundation of the State Key Laboratory of Fluid Power Transmission and Control (Grant No. GZKF-201614), Project of Natural Science Foundation of Shandong Province (Grant No. ZR2015EM042), Project of Shandong Province Higher Educational Science and Technology Program (Grant No. J14LB11) and Tai'an City Science and Technology Development Program, China (Grant No. 2017GX0033).

²Workshop 1 - State Key Laboratory of Mining Disaster Prevention and Control Co-founded by Shandong Province and the Ministry of Science and Technology, Shandong University of Science and Technology, Qingdao, Shandong 266590, China

³Workshop 2 - Department of Mechanical and Electronic Engineering, Shandong University of Science and Technology, Tai'an, Shandong 271019, China

⁴Workshop 3 - State Key Laboratory of Fluid Power and Mechatronic System, Zhejiang University, Hangzhou, Zhejiang 310027, China

⁵Corresponding author: Dongmin Li; e-mail: ldm753@163.com

drilling holes underground coal mine occurs occasionally, which may cause the damage to the drilling rig if the effective measures can not taken timely. Therefore the corresponding solutions on sticking for the drilling rod must be adopted to improve production safety underground coal mine and protect the drilling rigs and drilling rods.

In this paper, the hydraulic system of drilling rig is redesigned based on load sensing method, furthermore the model of the load sensing hydraulic system of the drilling rig is built with AMESIM, finally the drilling rig is controlled with fuzzy PID method, and the simulation on the whole system is done.

2. Structure of the drilling rig

The fundamental structure of the host of a typical drilling rig is shown in figure 1. The host consists of four parts, i.e., power head, holder, feeding device and chassis. Among that, the power head is mainly composed of hydraulic chuck, gear box and hydraulic variable motor, and the hydraulic chuck is adopted to clamp the drilling rod, thus the drilling bit drill in the holes underground coal mine due to the rotation of the hydraulic variable motor and transmission of the gear box. The holder is released when the operation of drilling holes starts, so that the drilling rod can be fed into the holes through the holder. The drilling rod is drilled into the holes and pulled away from the holes driven by the feeding device. The chassis is used to support the whole rig and install the feeding device, which is composed of base, upright column and support cylinder.

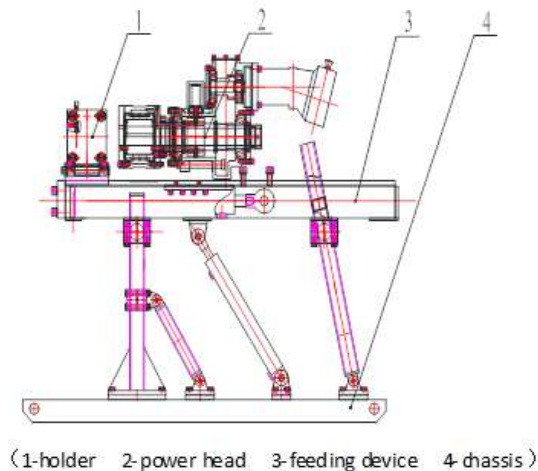

Fig. 1. The fundamental structure of the drilling rig

1-holder 2-power head 3-feeding device 4-chassis

3. Hydraulic loop with load sensing method

Load sensing method is used in the hydraulic system to sense the load and provide the pressure and flow rate corresponding to the load, and it works as follows: firstly, the shuttle valve network with multi-stage high pressure priority is used, and the maximum load pressure of the system is guided to the sensitive chamber of the differential overflow valve. The outlet pressure from the pump is higher than the maximum load pressure of the system at any time by automatically adjusting the overflow flow of the differential relief valve, and the pressure difference is determined by the pressure regulating spring of the differential overflow valve.

Based on the original hydraulic system of drilling rig, the load sensing system is added into the drilling rig hydraulic system, which is shown in figure 2.

Among that, HAWE PSV load sensing valve indexed with number 10 is controlled by the electric signals, and the flow and pressure in the system are depended on the multi-way valve and the load respectively, the maximum load pressure signal LS of all the reversing blocks are chosen by the shuttle valve and transferred to the variable mechanism of the load sensing variable pump. The variable mechanism adjusts the displacement of the variable pump according to the magnitude of the load pressure, so as to match output of pressure and the flow from the variable pump with the loads. When all the reversing blocks are in the middle position, the load sensing variable pump is unloaded and the system is in a standby state.

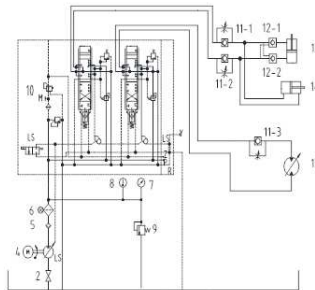

(1-tank 2-ball valve 3-hydraulic pump 4-electromotor 5-check valve 6-high pressure filter 7-pressure gauge 8-temperature gauge 9-relief valve 10-load sensing multi-way valve 11-one-way throttle valve 12- pilot operated check valve 13-feeding cylinder 14-support cylinder 15-hydraulic motor)

Fig. 2. Load sensing hydraulic loop of drilling rig

1-tank 2-ball valve 3-hydraulic pump 4-electromotor 5-check valve 6-high pressure filter 7-pressure gauge 8-temperature gauge 9-relief valve 10-load sensing multi-way valve 11-one-way throttle valve 12- pilot operated check valve 13-feeding cylinder 14-support cylinder 15-hydraulic motor

4. Fuzzy PID control method

Fuzzy control is a computer intelligent control method based on fuzzy set theory, fuzzy linguistic variables and fuzzy logic reasoning, and the basic concept was

proposed by L.A.Zadeh who is a famous professor at University of California in the United States^[4,5]. The basic principle block diagram is shown in figure 3.

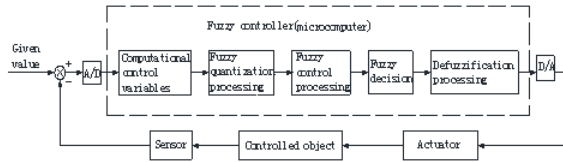

Fig. 3. Schematic diagram of fuzzy control method

Fuzzy controller for the drilling rig mainly is built as follows: firstly the input and output variables of fuzzy controller is determined, then the controller parameters such as correlation domain, quantization factor and scale factor are determined, furthermore the fuzzy control rules are formulated according to the actual experience, finally the fuzzy methods are determined.

4.1. Input and output variables of fuzzy controller

The input variables of the fuzzy controller for the drilling rig are the pressure deviation denoted with E and the increment of the pressure deviation denoted with ΔE from the feeding device, however the output variable is the pressure of the variable pump denoted with V . The fuzzy controller aims to combine the existing knowledge and experience, and the working condition of drilling holes is judged via fuzzy processing according to the deviation and the increment of the pressure during the drilling process. Then the pressure from the outlet of the hydraulic motor is output via defuzzification processing according to the fuzzy control rules, so as to improve the quality of drilling holes and decrease accidents of sticking for the drilling rod underground coal mine.

4.2. Variable fuzzification

The fuzzy controller has two input variables E and ΔE , an output variable V , but it still can be regarded as two-dimension fuzzy control system with single input and single output. The linguistic value of input variable E is divided into 7 levels, i.e., $E = \{NB, NM, NS, ZE, PS, PM, PB\}$, and it represents Negative Big, Negative Middle, Negative Small, ZERo, Positive Small, Positive Middle, Positive Big, and the variables ΔE and V are also divided into 7 levels, i.e., $\Delta E = \{NB, NM, NS, ZE, PS, PM, PB\}$, $V = \{NB, NM, NS, ZE, PS, PM, PB\}$ ^[6,7].

The fuzzy controller for the feeding force is designed with triangular membership function and fuzzy toolbox in Matlab, and the diagrams of the membership functions are shown in figure 4, 5 and 6.

Among that, the range of pressure deviation is $(-6,6)$, and the unit for the horizontal axis is MPa. And the range of increment of pressure deviation is $(-6,6)$ too, besides the range of pressure control is $(-2,10)$, and its unit is MPa. The membership function of E is expressed with triangle numbers except that ZE is expressed with trapezoid numbers.

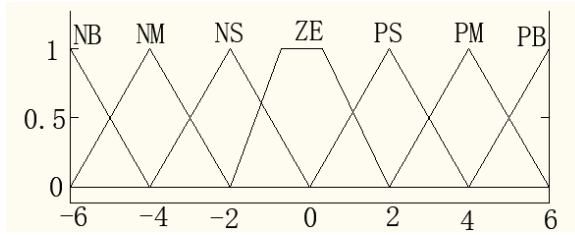

Fig. 4. Membership function of pressure deviation E

Fig. 5. Membership function of pressure deviation increment ΔE 

Fig. 6. Membership function of pressure V

And the triangle membership function is expressed with the following formula 1 and 2:

$$\mu(x) = (x - a) / (b - a), a < x < b \quad (1)$$

$$\mu(x) = (x - c) / (b - c), b < x < c \quad (2)$$

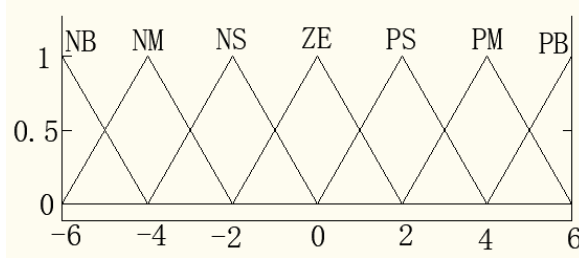
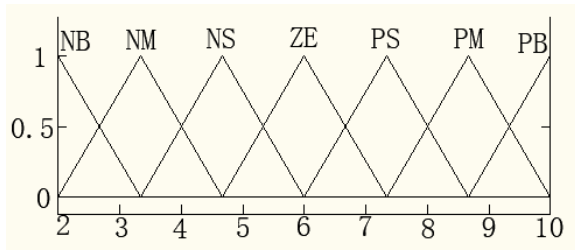
The trapezoid membership function is expressed with the following formula 3, 4 and 5:

$$\mu(x_2) = (x_2 - a) / (b - a), a < x_2 < b \quad (3)$$

$$\mu(x_2) = 1 \quad (4)$$

$$\mu(x_2) = (x - d) / (c - d), c < x < d \quad (5)$$

Among that, a, b, c are the turning point value of membership function in the

horizontal axis, and $\mu(x)$ is the membership degree in the vertical axis corresponding to the values in the horizontal axis.

The fuzzy control rule table of the feeding force of the drilling rig is compiled according to the fuzzy theory, which is shown in table 1.

Table 1 Inference table of fuzzy control rules

V		ΔE						
		NB	NM	NS	ZE	PS	PM	PB
E	NB	PB	PB	PB	PB	PM	ZE	ZE
	NM	PM	PM	PM	PM	PM	ZE	ZE
	NS	PM	PM	PM	PM	ZE	NS	NS
	ZE	PM	PM	PS	ZE	NS	NM	NM
	PS	PS	PS	ZE	NM	NM	NM	NM
	PM	ZE	ZE	NM	NB	NB	NB	NB
	PB	ZE	ZE	NM	NB	NB	NB	NB

The fuzzy control rule is expressed with the statement and written into the fuzzy controller, and its syntax is expressed as follows:

if (E is A) and (ΔE is B)
then (V is C)

The surface of the control rules can be got with fuzzy rules viewer of fuzzy toolbox in Matlab intuitively^[8], which is shown in figure 7.

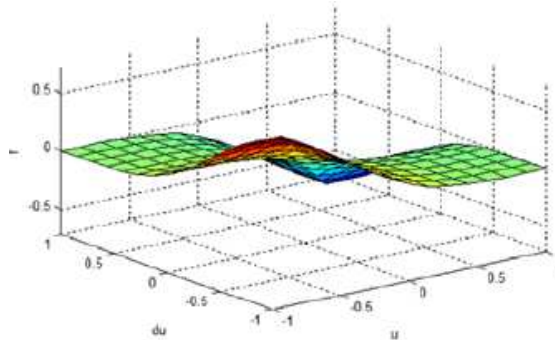

Fig. 7. Surface of the fuzzy control rule

5. Simulation on hydraulic system

Load sensing multi way valve and specific hydraulic loop is built with mechanical components library, hydraulic components library and HCD component library in AMESIM. The model of load sensing hydraulic loop of the drilling rig is built, then

the parameters of each component in the system are set, among that, the parameters of the variable pump are set as follows: the displacement, pressure, volume efficiency and the cut-off pressure is set as $68\text{cm}^3/\text{r}$, 28MPa , 0.98 and 30MPa . The load sensing hydraulic system of the drilling rig based on fuzzy PID method is shown in figure 8.

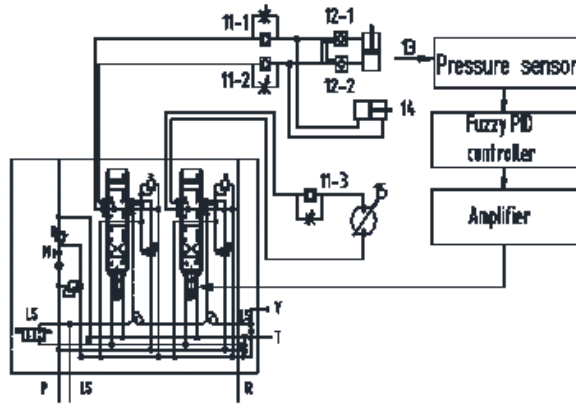

Fig. 8. Fuzzy PID control system

AMESim can encapsulate the complex systems due to its super component function, so it can drag simple icons placed in the application library with their own definition to replace the complex systems. The inner loop of the variable pump is encapsulated as a super element, and the package function of the feeding force and rotation torque of the drilling rig is inserted into Simulink in Matlab, so the corresponding logic controller is established^[9]. The final hydraulic loop of the joint simulation model is shown in figure 9.

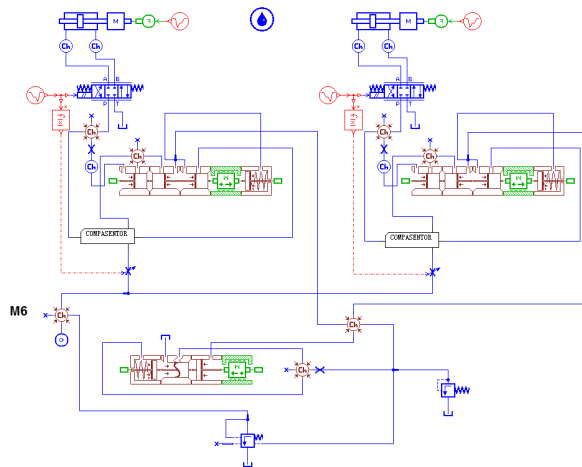

Fig. 9. Load sensing hydraulic loop for drilling rig

The simulation results are shown in figure 10 and 11, and the results can be got

from the simulation as follows:

When the time interval is between 0 and 5s, there is no external load, therefore the flow rate of the hydraulic pump and hydraulic cylinder are both zero, besides the pressure of the hydraulic pump increases slowly, and it is kept at pressure waiting state.

When the time interval is between 5 and 6s, the external load occurs, therefore the pressure of hydraulic cylinder rises rapidly, and there is demand on flow, meanwhile the flow of hydraulic pump increases rapidly until maximum flow.

When the time interval is between 6 and 16s, the flow rate of the hydraulic pump and hydraulic cylinder reach the maximum values, under the action of the external load, the pressure of hydraulic pump and hydraulic cylinder increase continuously.

When the time interval is between 16 and 22s, the external load becomes small, so the flow of hydraulic cylinder and hydraulic pump decrease synchronously, and the pressure increase continuously until maximum pressure.

When the time interval is between 22 and 28s, the external loads remain unchanged, so the flow rate and pressure of hydraulic pump and hydraulic cylinder remain unchanged.

When the time interval is between 28 100s, the external load becomes small, so the flow increases continuously until maximum flow, however the pressure reduces continuously until the minimum value.

From the above analysis, it can be seen that the flow and pressure of hydraulic pump and hydraulic cylinder always change with the loads, and the hydraulic system meets the requirements on the operation.

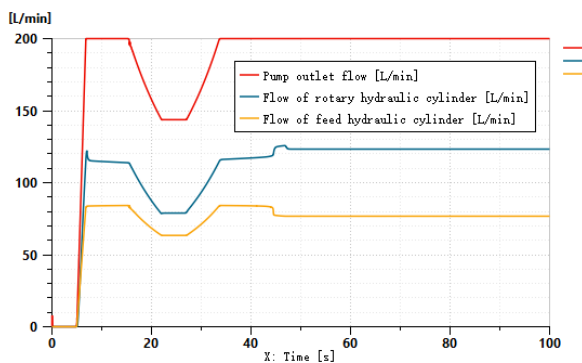

Fig. 10. Flow diagram of hydraulic pump and actuator

6. Conclusion

When the drilling rig encounters the complex geology situations during the drilling holes operation, it can not adjust the flow and pressure of the hydraulic pump in time, which easily leads to sticking for the drilling rod, even destroys safety operation underground coal mine. Aiming at the defect of the hydraulic system, a hydraulic system with load-sensing technology for the drilling rig is designed. Ac-

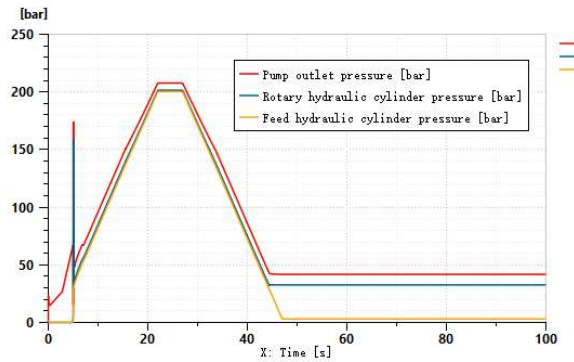

Fig. 11. Pressure diagram of hydraulic pump and actuator

According to the actual working conditions, PID control with AMESIM are applied to model the hydraulic system, and simulation results are got. The results show that the hydraulic loop is effective for solving sticking for the drilling rod and increasing the efficiency of operation of drilling holes.

References

- [1] W. WANG, B. WANG: *An energy-saving control strategy with load sensing for electro-hydraulic servo systems*. *Strojnicki vestnik* 62 (2016), No. 12, 709–716.
- [2] Y. ZHENG, W. R. REED, L. ZHOU: *Computational fluid dynamic modeling of a medium-sized surface mine blasthole drill shroud*. *Mining engineering* 68 (2016), No. 11, 43–49.
- [3] Y. L. CHEN, T. SHANG, J. L. LI: *Evaluation for energy-saving effect of hybrid drilling rig system based on the logic threshold method*. *Journal of terramechanics* 63 (2016), No. 1, 49–60.
- [4] Y. X. SU, C. H. ZHENG: *PID control for global finite-time regulation of robotic manipulators*. *International journal of systems science* 48 (2017), No. 3, 547–558.
- [5] Y. D. WANG, M. J. YANG, G. J. WEN: *Automated three-dimensional design of the chuck of core drilling rigs*. *Advances in Mechanical engineering* 8 (2016), No. 10, 1–10.
- [6] Y. Z. ZHANG, J. M. ZHANG, Z. J. SHI: *Application and development of numerical simulation for underground horizontal directional drilling*. *Journal of coal science and engineering* 18 (2012), No. 1, 1–10.
- [7] N. L. KHOBRADE, K. C. DESHMUKH: *An asymptotically stable pressure observer based on load and displacement sensing for pneumatic actuators with long transmission lines*. *IEEE/ASME transactions on mechatronics* 22 (2017), No. 2, 681–692.
- [8] Y. F. ZHOU, Z. M. WANG: *MDPRE Solution for drilling rig sticking*. *International journal of automation technology* 10 (2016), No. 5, 827–834.
- [9] D. Z. XIN, S. L. CHEN, Q. F. WANG: *Technology of load-sensitivity used in the hydraulic system of an all-hydraulic core rig*. *Journal of coal science and engineering (China)* 15 (2009), No. 3, 318–323.

Received November 16, 2017

